

# TELECOMMAND AND TELEMETRY COMPONENTS FOR TODAY AND TOMORROW

P. Sinander, S. Habinc

*Control, Data and Power Division, Directorate of Technical and Operational Support  
European Space Agency, PO. Box 299, NL-2200 AG, The Netherlands  
phone: +31-71-565 65 65, fax: +31-71-565 4295  
e-mail: psi@ws.estec.esa.nl, sandi@ws.estec.esa.nl*

## ABSTRACT

*The CCSDS Telecommand (TC) and Telemetry (TM) standards are today being employed for a large number of scientific and commercial spacecraft. Using this standard allows reduced costs for on-board, ground and test equipment, as well as for spacecraft testing and in-orbit operation. This paper introduces the CCSDS/ESA standards, and presents the supporting standard components developed by ESA and a typical TM/TC system based on these components. Some examples of spacecraft using these components are then given.*

*To round off the paper a new concept for essential telemetry retrieval is introduced. Some issues for future developments of TM/TC components are listed, intended as a first input for discussions on the development approach and priorities. The objective would be to allow significant reduction in spacecraft cost by higher level of integration and by allowing the same equipment to be used for commercial and scientific spacecraft.*

## 1. PACKET TELECOMMAND

The purpose of Telecommand is to control the spacecraft behaviour from a remote location, usually being a ground station. The fundamental capabilities include a direct control of the critical spacecraft functions, referred to as Direct Telecommand, and the provision of commands and data to the Data Handling computer and/or other subsystems on-board the spacecraft.

### 1.1 ESA/CCSDS standard

The ESA Packet Telecommand Standard [1] is directly derived from the corresponding CCSDS standard, and defines the requirements on error detection and correction, protocols for the data transfer, etc. The accompanying Telecommand Decoder Specification [2] specifies standard interfaces for the TC Decoder, as well as complementary functions such as the Command Pulse Distribution Unit (CPDU) and a procedure for authentication of the telecommand segments.

The Packet Telecommand (TC) Frame has a variable length, each TC Frame containing exactly one TC Segment. A TC Segment consists of a one-byte Segment Header followed by the rest of the segment, which can be a (part of a) Packet, or another type of data structure. Packets and data structures longer than 249 bytes must be transmitted using several TC Frames. The five-byte TC Frame Header contains the Spacecraft Identifier, the sequence count etc. The complete TC Frame is protected against data corruption using a 16-bit Cyclic Redundancy Check (CRC) word.

To improve the frame rejection ratio the TC Frame is split into seven-byte parts, each part having an added one-byte error correcting Bose-Chaudhuri-Hocquenghem (BCH) code, together forming a number of eight-byte Code Blocks. The last Code Block is normally completed with a fill pattern after the last byte of the TC Frame, in order to obtain exactly eight bytes. All Code Blocks making up one TC Frame preceded with a 16-bit Start Sequence and ended with a Tail Sequence (a Code Block with multiple errors) are called a Command Link Transfer Unit (CLTU), shown in figure 1.

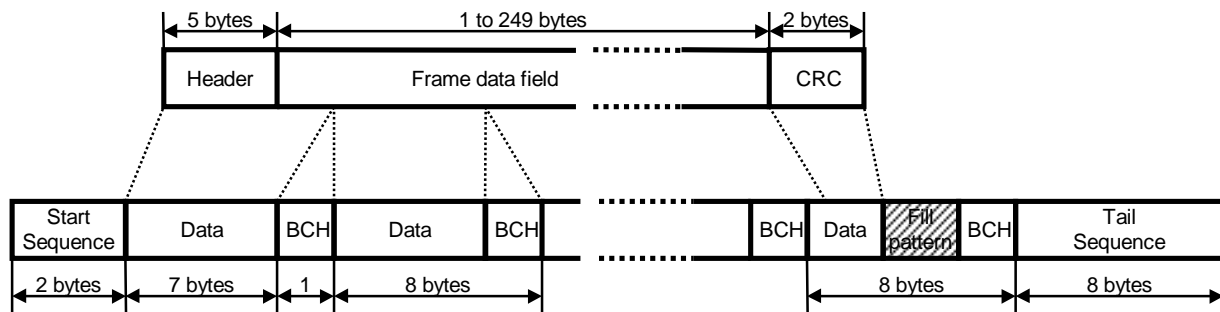

Figure 1: Telecommand CLTU

There are three types of TC Frames:

- AD ("Automated Data") Frames utilise a protocol with sequence verification and automatic retransmission called COP-1, ensuring that the TC Segments are received in the correct order;
- BC ("Bypass Control") Frames are used to control the on-board part of the COP-1 protocol machine;
- BD ("Bypass Data") Frames are accepted without the sequence control.

In order for the COP-1 protocol to work properly the Command Link Control Word (CLCW) is provided to the ground as part of the TM Frame trailer. In case of down-link failure, BD Frames can be used bypassing the automatic sequence control.

## 1.2 The Packet Telecommand Decoder (PTCD)

The Packet Telecommand Decoder (PTCD) is a radiation hard, latch-up free single-chip implementation of a TC Decoder core. The PTCD is a full implementation of, and fully compliant with, the relevant ESA standards [1] [2]. It is manufactured in the MITEL SOS5 CMOS/SOS technology, having low power consumption and very low Single Event Upset (SEU) sensitivity. It is packaged in a 132-pin ceramic quad flat-pack. The PTCD will be available as an Application Specific Standard Product (ASSP) from MITEL Semiconductor under device number MS13545 in August 1998.

The PTCD replaces the MA28140 PTD device discontinued by GEC-Plessey Semiconductors in the beginning of 1998. It is a direct transfer of the PTD design, functionally identical with two minor enhancements, using the same package and pinout, although with a change from TTL levels to CMOS levels on some inputs. The PTCD is therefore virtually "drop-in" compatible with the previous PTD device.

The PTCD has six inputs supporting a maximum bit rate of 100 kbit/s, also when authentication (see below) is enabled. Higher bit rates are possible, although retransmission could be required for worst-case sequences of minimum and maximum length TC Segments. The PTCD is searching for the Start Sequence on all inputs simultaneously, until it is detected at one of the inputs. It then accepts all Code Blocks of a CLTU from that input, correcting single-bit errors when detected, and removing the error correcting codes. When the Tail Sequence is detected, the PTCD resumes searching for a new Start Sequence on all inputs.

The received candidate TC Frame is verified w.r.t. to CRC, frame length, spacecraft identifier etc. If it is an AD Frame, it will only be accepted if in correct sequence. If necessary, retransmission of missing AD Frames is requested through the CLCW. Accepted TC Segments are output through either a serial Multiplexed Access Point (MAP) interface or a 16-bit CPU-type parallel interface. The MAP identifier contained in the TC Segment Header is an address for directing the TC Segment to one of 64 different destinations.

The PTCD has an on-chip Authentication Unit (AU), which when enabled prevents unauthorised commanding of the

spacecraft. The AU verifies a 5-byte signature placed after each TC Segment to be authenticated. The signature is calculated using a complex "unbreakable" algorithm. Which MAP addresses require authentication is selectable. Alternatively, an external AU can be connected to the PTCD, in case another authentication algorithm or TC Segment encryption is required.

The PTCD on-chip Command Pulse Distribution Unit (CPDU) is intended for critical control of the spacecraft, referred to as Direct Telecommand. After verifying the CPDU Packet in the TC Segment, the CPDU sequentially executes the commands contained in it (up to 120 commands in one CPDU Packet). For each command one of 256 outputs is activated for a specified time.

The following status reports are available from the PTCD:

- Part of the Command Link Control Word (CLCW);
- The Frame Analysis Report (FAR);
- The AU Status Report (AUSR);
- The CPDU Status Report (CPDUSR).

The CLCW is required for proper operation of the AD service, and the PTCD has two redundant serial interfaces which are directly compatible with the TM Encoder (see further on). The three other reports can be retrieved by the Data Handling computer either using a serial interface or the same parallel interface as for the TC Segments. They are valuable for subsystem testing on ground and for determining the TC Decoder status in-flight.

The PTCD automatically starts operating after power-on without any programming being needed. All mission specific parameters are stored in an external Programmable Read Only Memory (PROM). In addition, an external two Kbytes Random Access Memory (RAM) is needed for temporary storage of the received TC Frames. Since the TC Decoder is the only control connection from ground, it must always be operational and shall never be switched off or reset in-flight.

## 2. PACKET TELEMETRY

The purpose of Telemetry is to provide status and data from the spacecraft platform and payload to a remote location, usually being a ground station.

### 2.1 ESA/CCSDS standard

The ESA Packet Telemetry Standard [3] is directly derived from the corresponding CCSDS standard. The Packet Telemetry Frame has a fixed, mission-dependent length. The original CCSDS standard TM Frame length for cross support is 1115 bytes, but in principle any Frame length is possible. When using Reed-Solomon encoding, the TM Frame length should preferably be a multiple of 223 bytes. Since the TM Frame length is fixed and the packets can be of variable length, the TM Frame Header contains a pointer to where in the TM Frame the first packet is located. Subsequent packet positions within the TM Frame can then be found by adding the packet lengths. Since the packet can be much smaller or larger than the Frame, a TM Frame can contain many small

packets, or only a part of one large packet. The six-byte Primary Header contains Spacecraft Identifier, sequence counts etc. When enabled, the optional four-byte Secondary Header contains an extension to the Virtual Channel sequence count.

In a Packet TM/TC system the CLCW from the TC Decoder is transported as part of the TM Frame Trailer. The TM

Frame must be error-protected since an error in the CLCW status will disturb the COP-1 protocol. The TM Frame preceded by a 32-bit Synchronisation Marker and optionally followed by the Reed-Solomon codes is called a Channel Access Data Unit (CADU), shown in figure 2.

As for the TC frame, in addition to packets any other data structure can be in principle be transported in the TM Frame.

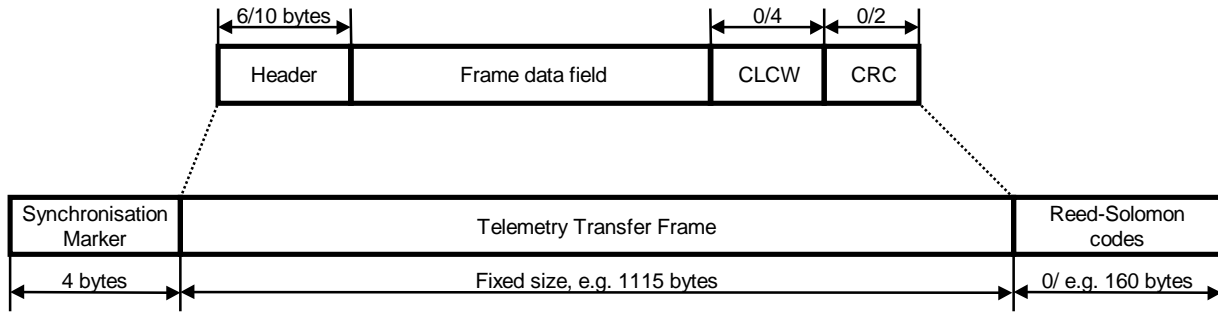

**Figure 2:** Telemetry CADU

## 2.2 The VCA and VCM

The Virtual Channel Assembler (VCA) and the Virtual Channel Multiplexer (VCM) are radiation-hard, latch-up free devices for implementing a Telemetry Encoder fully compliant with the ESA/CCSDS Packet TM standard [3]. They are manufactured in the MITEL SOS4 CMOS/SOS technology, having low power consumption and very low SEU sensitivity. Both are packaged in 84-pin ceramic quad flat-packs. The VCA and the VCM are available as ASSPs from MITEL Semiconductor under device numbers 12399 [4] and 12396 [5] since 1994.

Data can be received on up to eight Virtual Channels, where each Virtual Channel can be seen as an independent communication link. Each Virtual Channel requires a VCA together with an external eight Kbytes RAM for temporary buffering of the TM Frames. The VCA has an eight-bit parallel input interface, or alternatively a serial input interface similar to the MAP interface of a TC Decoder can be used. The maximum burst input data rate is 25 Mbit/s. The VCA can optionally generate and insert Idle TM packets into the TM Frame in order to fill it up. This feature can be used to ensure that the last packets in an incomplete TM Frame will be sent to the ground when there is no more data to be input to the VCA, for example when an instrument has been turned off.

Data from the VCAs is time multiplexed on a frame basis by the VCM. The VCM has two built-in algorithms for selecting which VCA to output the next TM Frame; Bandwidth Allocation respectively Priority Selection. Bandwidth Allocation guarantees a minimum bandwidth for each Virtual Channel. Priority Selection always selects the Virtual Channel with the highest priority. The bandwidth, respectively the priority, can be reprogrammed in-flight.

Alternatively, an arbitrary selection algorithm can be implemented externally. Since the VCM is continuously outputting CADUs without interruption, an Idle TM Frame is generated by one of the VCAs whenever there is no complete TM Frame with data available.

The VCA and VCM together generate the Synchronisation Marker, the TM Frame Header including the First Header Pointer (allowing the position of the packets within the Frame to be located), and the optional TM Frame Trailer. If required, Reed-Solomon codes can be appended to each TM Frame using an external Reed-Solomon Encoder (see section 3.1). The chip set supports four different TM Frame lengths: 223, 446, 892 and 1115 bytes, covering a useful range of lengths which can be used both with and without Reed-Solomon encoding. The maximum output bit rate is 12.5 Mbit/s. Four TM Frame Trailer options are supported: no TM Trailer, CLCW, CRC or both CLCW and CRC. The CLCW is retrieved from a TC decoder using a built-in interface, which can be directly connected to one of the PTCDC CLCW interfaces. In redundant configurations it is possible to automatically toggle the CLCW retrieval between two TC decoders.

The VCA generates a time strobe to be used for the spacecraft time correlation. The intervals are programmable in accordance with the ESA Packet Telemetry standard. The strobe can be used to sample the on-board spacecraft time at a defined position in the TM Frame. The sampled time is then sent to ground, where it is compared with the ground time sampled at the same position in the TM Frame. The spacecraft and ground time can then be correlated by comparing the two samples.

The VCA and VCM devices are operational after power-on without needing any programming.

### 3. TELEMETRY CHANNEL CODING

#### 3.1 ESA/CCSDS standards

The ESA Telemetry Channel Coding standard [6] is directly derived from the CCSDS Telemetry Channel Coding recommendation. It specifies the Reed-Solomon and Convolution Encoding to be used in conjunction with the Packet Telemetry standard.

The CCSDS telemetry channel coding standard is currently being revised to accommodate turbo coding. A pink sheet updating the standard is expected in 1998, establishing turbo coding as an alternative to Reed-Solomon and Convolutional coding.

#### 3.1 RESCUE Reed-Solomon and Convolutional Encoder

The Reed-Solomon and Convolutional Encoder (RESCUE) is a radiation-hard, latch-up free device directly compatible with the VCA/VCM chip set for the TM Encoder. It is manufactured in the MITEL SOS5 CMOS/SOS technology, having low power consumption and very low Single Event Upset (SEU) sensitivity. It is packaged in a 28-pin gull-wing flat-pack. The RESCUE will be available as an Application Specific Standard Product (ASSP) from MITEL Semiconductor under device number MS13544 in August 1998.

The RESCUE replaces the MA1916 device discontinued by GEC-Plessey Semiconductors in 1997. The RESCUE is a new design, which can operate in a basic mode largely compatible with the MA1916. To ensure backwards compatibility, the new design has been thoroughly verified versus the MA1916 device using a hardware modeller. When configured in its advanced mode it has several enhanced capabilities, including:

- Interleave depths from one to eight;
- Suppression of information data, allowing shortened TM frames;

- Pseudo-randomiser;
- NRZ-M encoding of output symbols.

It can operate up to 17 Mbit/s data rate, with an output rate up to 34 Mbit/s when the Convolutional Encoder is enabled. The RESCUE device is further described in [7].

#### 3.2 Turbo encoder

A turbo encoder is currently being developed at the European Space Research and Technology Centre (ESTEC) as a technology independent synthesizable core. This development is expected to be finalised by the end of 1998. As a first step to demonstrate the core it will be implemented in a Field Programmable Gate Array (FPGA), using an external buffer RAM. An Application Specific Integrated Circuit (ASIC) implementation with on-chip buffer memory could then be developed depending on the need and available funding. The Turbo encoder is further described in [8].

### 4. A TYPICAL TM/TC SUBSYSTEM

An overview of a typical TM/TC subsystem is shown in figure 3 (without redundancy). The figure shows a receiver, a TC decoder, a TM Encoder, a transmitter, a Data Handling computer, a mass memory and some on-board Users (e.g. other subsystems and payloads).

Each receiver demodulates the Radio Frequency (RF) signal and provides a bit-stream containing CLTUs to the TC Decoder. The CLTUs are decoded by the TC Decoder, and accepted TC Segments are provided to the Data Handling computer. The TC segments are either consumed in this computer or further distributed to the Users. Alternatively, TC Segments could be sent directly to some Users. The TC Decoder also generates status reports which can be read by the Data Handling computer.

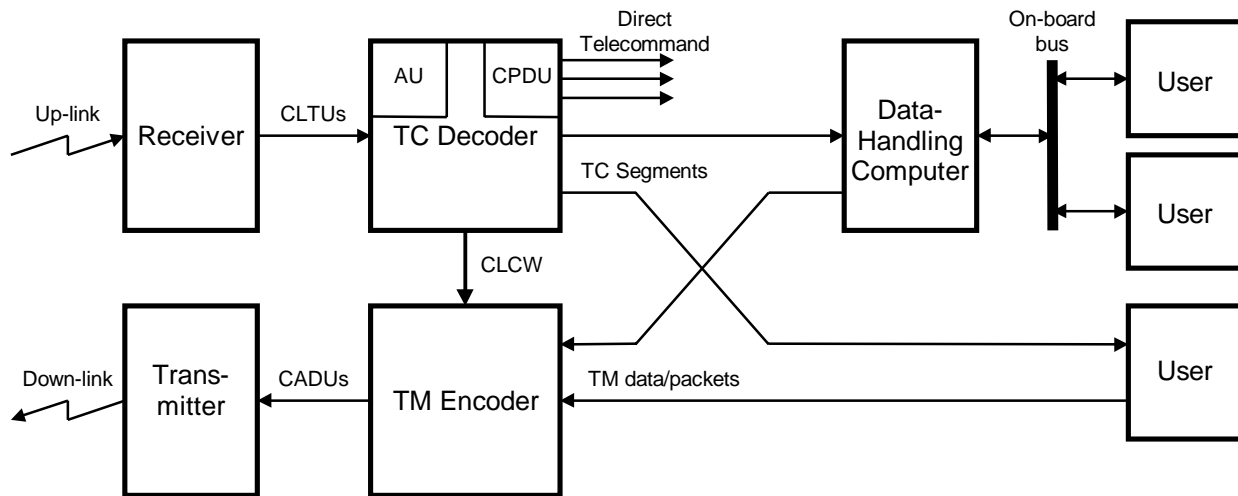

Figure 3: Typical TM/TC System

Data from the Data Handling computer is fed to the TM Encoder which generates the TM CADUs. Data from on-board Users can be sent via the Data Handling computer, or alternatively directly to the TM Encoder. The CLCW is automatically retrieved from the TC Decoder and inserted into the TM Frame trailer. The transmitter receives CADUs from the TM Encoder, which are then modulated and sent to the ground.

If data cannot be sent to the ground at all times or is not regularly produced, data is temporarily stored in a mass memory acting as a buffer, normally placed before the TM Encoder (not shown in figure 3).

#### 4.1 Telecommand Decoder

A block diagram of a TC decoder is shown in figure 4. In addition to the PTCDD the following components are needed:

- One 1k by 8 PROM containing the mission specific parameters such as spacecraft identifier, and the authentication key when the AU option is enabled;
- One 2k by 8 RAM to temporarily store the received TC segments;
- Circuitry for de-multiplexing and amplifying the CPDU signals, consisting of 54-series standard logic and power drivers;

- Circuitry for distributing the TC Segments according to the MAP address, consisting of 54-series standard logic. In case the parallel microprocessor interface is used, no additional circuitry is needed.

#### 4.2 Telemetry Encoder with Channel Coding

A block diagram of a TM Encoder is shown in figure 5, consisting of:

- One VCA per Virtual Channel;
- One 8k by 8 SRAM of standard type per Virtual Channel, to temporarily store the Frames (7 to 36 Frames depending on TM Frame length);
- One VCM;
- One RESCUE when Reed-Solomon and/or convolutional encoding is required.

In this example four Virtual Channels have been used: VC0, VC1, VC2 and VC7. VC0 - normally used for house-keeping data sent from the Data Handling computer - and VC1 have 8-bit parallel interfaces. VC2 and VC7 have serial interfaces, for example for connecting remote sub-systems.

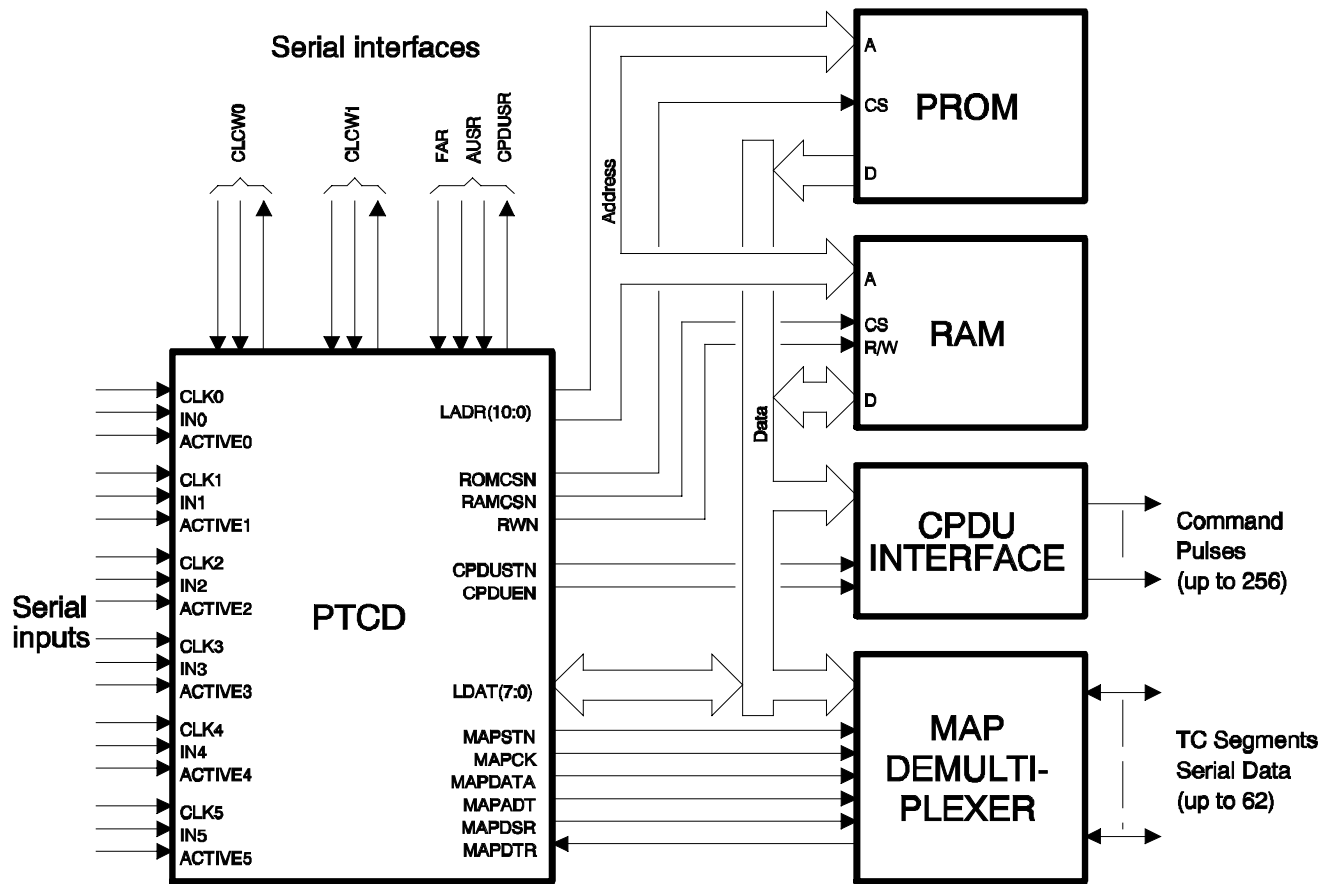

Figure 4: Telecommand Decoder with the PTCDD

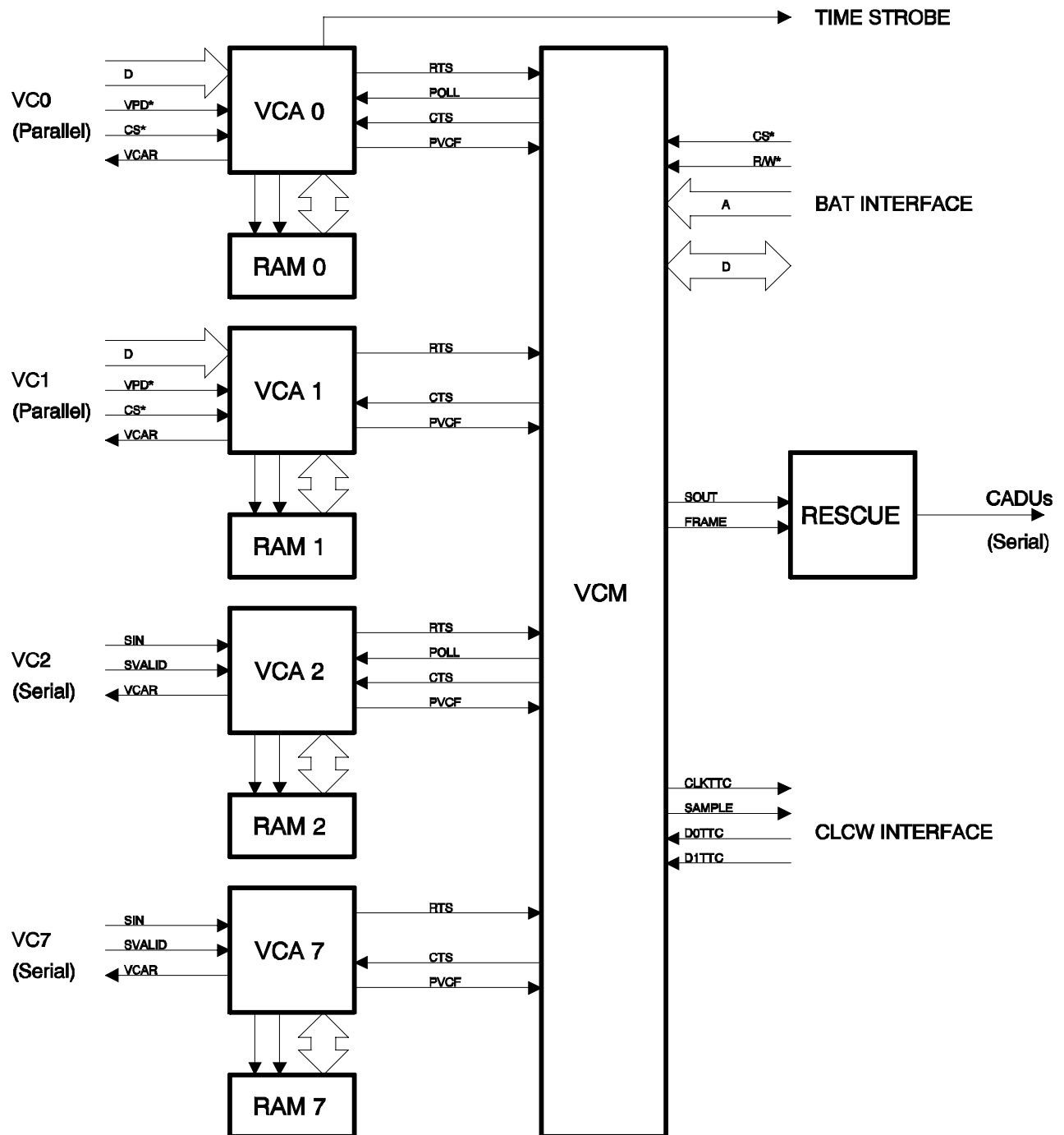

Figure 4: Telemetry Encoder with the VCA, the VCM and the RESCUE

### 4.3 Spacecraft using the ESA components

Due to their commercial availability to any company directly from the foundry, the components described in this paper have been employed in a large number of different spacecraft. The projects range from ESA and national developments to commercial developments. An incomplete list of spacecraft using some or all of these components at the time of writing (mid 1998) include Abrixas, ATV, Champ,

EuroStar, Integral, LeoStar, METOP, MSG, Proba, Proteus, Rosetta, SeSat, SMART-1, STRV, TeamSAT and XMM.

The first in-flight usage of the PTD, the VCA and the VCM was on-board TeamSAT in 1997 [9], also demonstrating the operation with a Packet TM/TC ground-station.

## 5. LOOKING INTO THE FUTURE

### 5.1 Essential Telemetry retrieval

The PETRA (Packetised Essential Telemetry Retrieval ASIC) is a single-chip low-power device automatically retrieving essential spacecraft status and sensor data. One single PETRA directly connects to up to 40 digital and/or up to 32 analog sensors, which are periodically scanned. The resulting data is formatted into CCSDS packets which can be sent directly to the Telemetry Encoder and/or to the on-board Data Handling computer. Immediate operation after power-on without any programming being needed allows the spacecraft status to be determined even if major parts of the Data handling System is not operational.

The current PETRA is a concept demonstrator, implemented in commercial technology by Silicon Systems Limited (SSL) [10]. SSL is looking into the possibilities to develop a radiation hard version of the PETRA. Before the PETRA chip was available, the PIA (PETRA In Actel) was flown onboard TeamSAT last year, being the first in-flight demonstration of the concept [9].

### 5.2 The next level of integration

As shown in this paper, the ESA chip set for TM/TC is being maintained by replacing discontinued components with replacements which are functionally, pin and mechanically compatible. However, at some time in the future it will no longer be adequate to stay at the current level of integration, but instead continue to a significantly higher level. In order of importance, the main objectives of such a development would be:

1. To allow significant reduction of spacecraft non-recurring and recurring costs, by
  - a) using same hardware for commercial and scientific spacecraft, thus allowing economy of scale;
  - b) reducing manufacturing costs (e.g. for components, assembly, housing, etc.);
  - c) reducing the effort for validation and verification by using a standard already validated device.
2. To allow shortened spacecraft development time. As software becomes more complex, increasingly it will be completed later in the development cycle. By allowing the design of a TM/TC system with an inherently safe mode without any software being required, remote uploading and booting of the spacecraft computer will be feasible. Thus spacecraft integration, testing, delivery and in extreme cases even launch could be performed while the software is being finalised.
3. Increased functionality and performances, as long as not impairing the above two objectives.

The issues listed below shall be seen as a first input for the definition of a future Telecommand Telemetry Chip (TTC). They are only preliminary and are subject to further analysis and discussions.

It is envisaged that the TTC would contain a TC decoder, a TM Encoder with channel coding, and a variety of suitable interfaces to the Data Handling System. It would probably

also be advantageous to integrate data demodulation and modulation, and possible even parts of the Intermediate Frequency (IF) digital signal processing.

The up-link and the TC Decoder:

- Input bit rate up to 4 Mbit/s (256 kbit/s with AU);
- Each layer (physical, coding, transfer frame, etc.) should be possible to enter and exit, allowing bypass or external implementation of that layer, as well as introducing intermediate layers;
- Support for ranging;
- PSK, QPSK and/or FQPSK demodulation on (say) four input channels;
- Optional Reed-Solomon or convolutional decoding as an alternative to the BCH decoding;
- Implement the CCSDS Packet Telecommand standard as well as commercially important protocols. Multiple COP-1/FARM-1 protocol machines to be considered depending on real need;
- Same built-in AU with option to use external one;
- Superset CPDU, with multiple outputs simultaneously active, wider range of activation times ( $\mu$ s to s), and some on-chip outputs;
- Multiple output interface types, such as the MAP interface, RS-232 type asynchronous serial interface, and parallel microprocessor interface (shared with the TM functions).

The TM Encoder and the down-link:

- Output bit rate up to 50 Mbit/s;
- Multiple input interface types, such as the MAP/VCA interface, RS-232 type asynchronous serial interface, parallel microprocessor interface, and possibly a speed limited version of the IEEE-1355 serial interface;
- Packetisation service for non-packet data;
- Automatic packetisation of the TC Decoder reports and insertion into a Virtual Channel;
- Packet multiplexing into one Virtual Channel as an alternative to using separate Virtual Channels;
- Only one Idle Packet to be inserted into a frame instead of many small; either standard Idle Packets (which could spill over) or non-standard exact size Idle Packets;
- Independent buffer size for each Virtual Channel up to 128 Kbytes, support of up to four external buffer RAMs from 8 Kbytes to 128 Kbytes capacity;
- Implement the CCSDS Packet Telemetry standard, a subset of the CCSDS AOS Packet Telemetry standard and possibly a subset of Packet TC frames (to allow bidirectional communication);
- Allow any external algorithm for bandwidth allocation
- Support of different secondary headers, e.g. for low-latency transport of essential telemetry;
- Reed-Solomon, convolutional and/or Turbo encoding;
- Pseudo-randomiser;
- PSK, QPSK modulation;
- Each layer (physical, coding, transfer frame, etc.) should be possible to enter and exit, allowing bypass or external implementation of that layer, as well as introducing intermediate layers;
- On-chip or external bit rate generator.

## 6. CONCLUSIONS

The Packet Telecommand and Packet Telemetry standards have been introduced. The ESA components for implementing fully compliant Telecommand Decoders and Telemetry Encoders have been presented. These components allows the Packet Telecommand and Packet Telemetry standards to be easily implemented in spacecraft. They have been flight proven in 1997, and are being used in a large number of ESA, national and commercial spacecraft.

The objectives for the next level of integration of TM/TC subsystems were presented, being significantly reduced spacecraft cost, reduced development time, and some functionality and flexibility enhancements. A number of issues have been listed as a first input to further discussions and definition work of a single Telemetry and Telecommand Chip.

## 6. REFERENCES

1. *Packet Telecommand Standard*, ESA PSS-04-107 Issue 2, European Space Agency, April 1992
2. *Telecommand Decoder Specification*, ESA PSS-04-151 Issue 1, European Space Agency, September 1993
3. *Packet Telemetry Standard*, ESA PSS-04-106 Issue 1, European Space Agency, January 1988
4. *Virtual Channel Assembler VCA HAF\_12399 Data Sheet*, ABB Hafo (now MITEL Semiconductor), January 1994
5. *Virtual Channel Multiplexer VCM HAF\_12396 Data Sheet*, ABB Hafo (now MITEL Semiconductor), January 1994
6. *Telemetry Channel Coding Standard*, ESA PSS-04-103, Issue 1, European Space Agency, September 1989
7. *RESCUE - A Radiation Hard CCSDS Reed-Solomon and Convolutional Encoder Device*, S. Habinc, proceedings of TTC'98, European Space Agency, 1998
8. *Development Plan for Turbo Encoder Core and Devices Implementing the Updated CCSDS Telemetry Channel Coding Standard*, S. Habinc et al, proceedings of TTC'98, European Space Agency, 1998
9. *The TeamSAT Data Handling System*, C. Smith et al, proceedings of TTC'98, European Space Agency, 1998
10. *An Autonomous CCSDS Packet Generating ASIC for Analog and Digital Telemetry*, D. Reddy et al, proceedings of TTC'98, European Space Agency, 1998

Summary information on the components presented here together with some related papers can be found at the ESA microelectronics web page <http://www.estec.esa.nl/wsmwww>. For additional information and Data Sheets contact the sales manager IC products at MITEL Semiconductor (Sweden), phone +46-8-58 02 45 00, fax +46-8-58 02 01 90.